

BIS 12mm All In - IKS 5-2-20

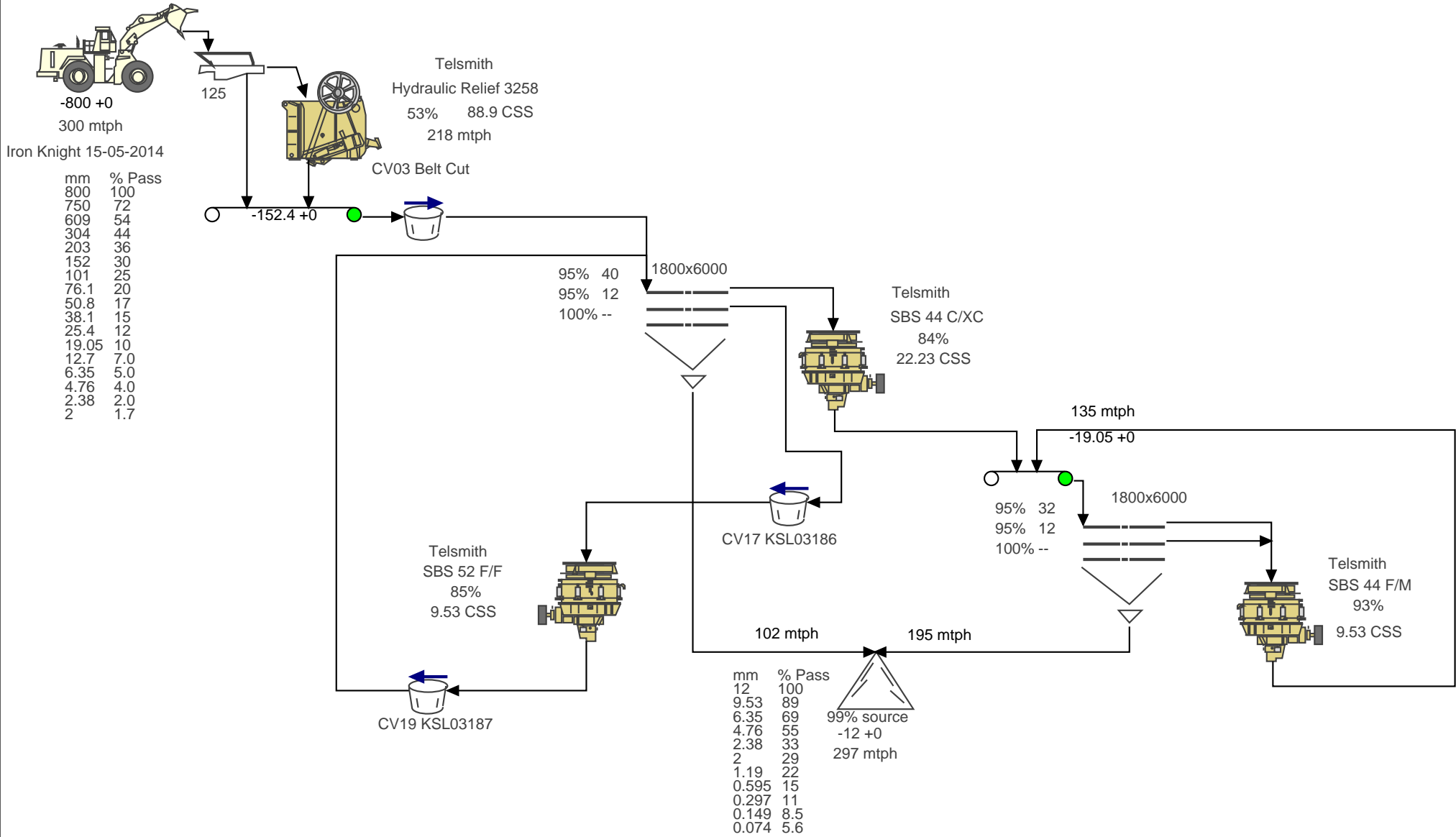

Mode: All in Fines Mode

Calculation results may differ due to variations in operating conditions and application of crushing and screening equipment. This information does not constitute an express or implied warranty, but shows results of calculations based on information provided by customers or equipment manufacturers. Use this information for estimating purposes only.

All calculations performed by AggFlow. <http://www.AggFlow.com>

Astec Australia

BIS IKS Current Plant Set-UP

Adam Gordon

12mm All In - 5-2-20:

Project #: 51605 Revision #: 407282 Date: 5/February/2020